

GREEN'UP

YOUR ELECTRIC VEHICLE

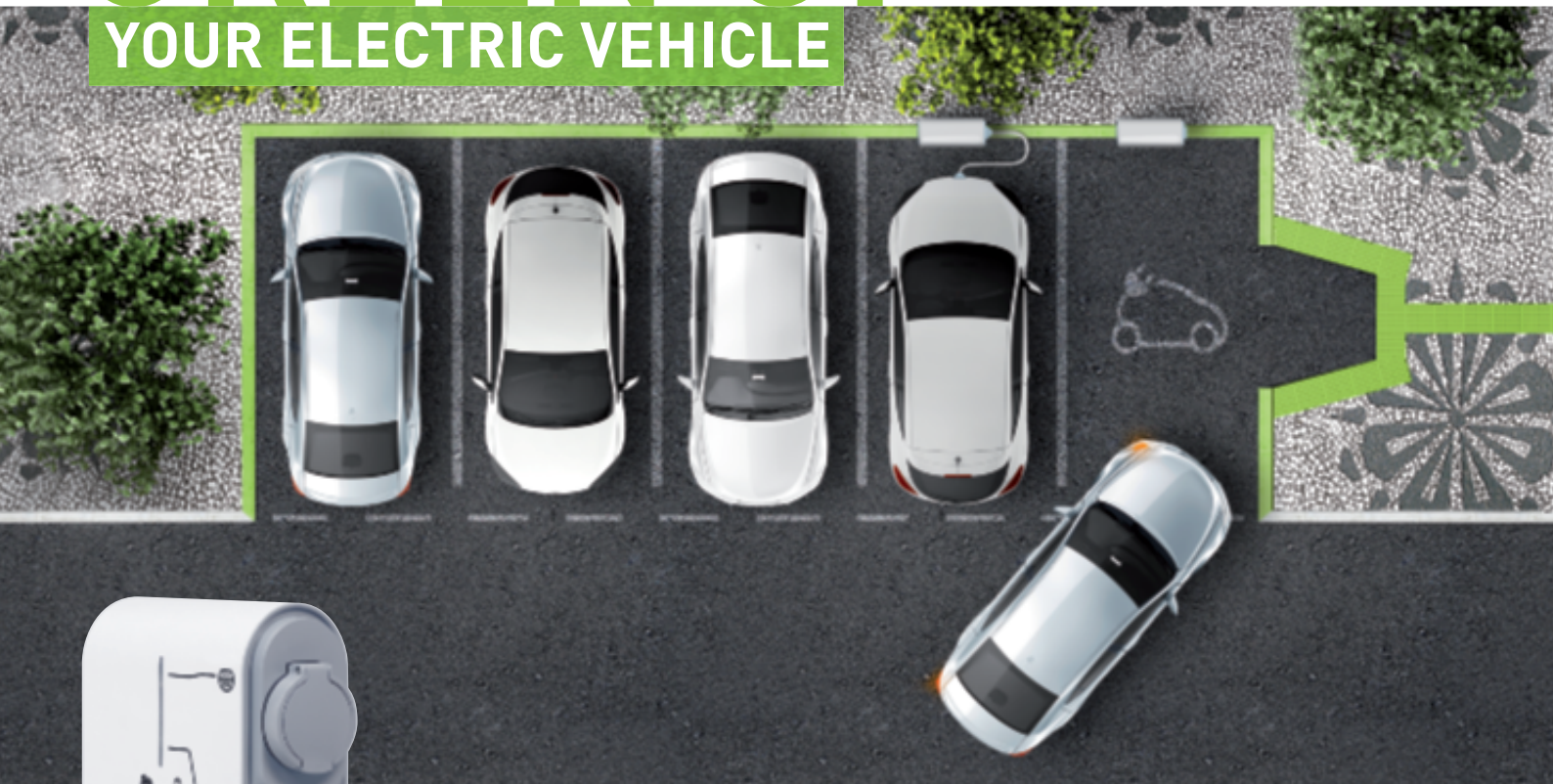

CHARGING SOLUTIONS
FOR ELECTRIC VEHICLES
OR PLUG-IN HYBRIDS

THE GLOBAL SPECIALIST IN ELECTRICAL
AND DIGITAL BUILDING INFRASTRUCTURES

 **legrand**[®]

which infrastructure for normal charging?

VEHICLE MANUFACTURER

ELECTRIC VEHICLE

CABLE SUPPLIED WITH THE VEHICLE

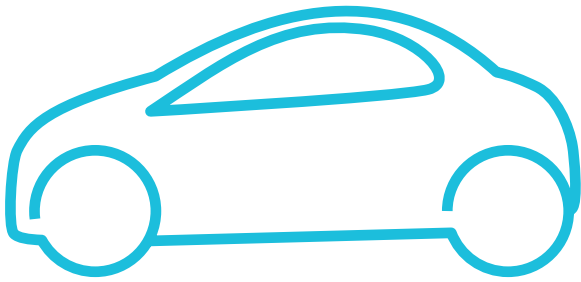

MODE 2



UNSHUTTERED
PLUG

PLUG suitable
for unshuttered
vehicle coupler

MODE 3



T2 PLUG

BUILDING ELECTRICAL INFRASTRUCTURE

CHARGING SOCKET



Green'up Access socket
14 A - 3.2 kW single-phase

Dedicated line with single-phase
30 mA
20 A RCBO



7 hrs with Green'up Access plug/socket
12 hrs with any other plug

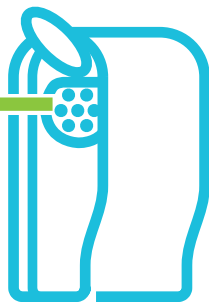

Green'up Premium charging station
3.7 to 7.4 kW single-phase

Safety contact

Dedicated line with single-phase
30 mA
20 A to 40 A RCBO

Pilot wire for off-peak signal or clock



3.7 kW single-phase



7.4 kW single-phase

(1) Average time for full charge according to manufacturer sources, variable depending on the model

Select your charging solution for residential or commercial buildings

2

GREEN'UP CHARGING SOLUTIONS

IK 08 AND IK 10 GREEN'UP ACCESS SOCKET

MODES 1 & 2

Charging time



IP 55 - IK 08
14 A - 3.2 kW
single-phase

IP 55 - IK 10
14 A - 3.2 kW
single-phase

8 to 14 A charging in complete safety
of all electric vehicles with a mode 1 or
mode 2 cable, regardless of how much
charging power is required by the vehicle

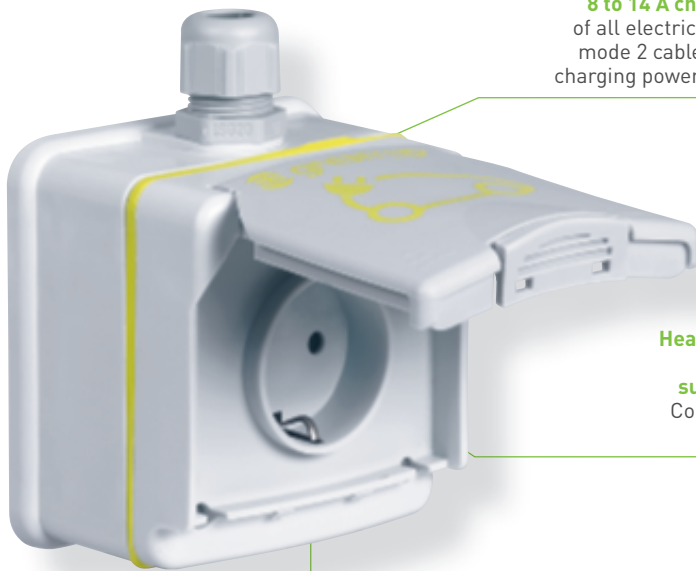

**Heavy-duty socket, identified
for electric vehicles, also
suitable for any application**
Conforms to NF C 61314 and
the LCIE test programme

IK 08 socket



Optimum safety
Surface treatment of
metal contacts
to improve electrical
conductivity



IK 10 socket

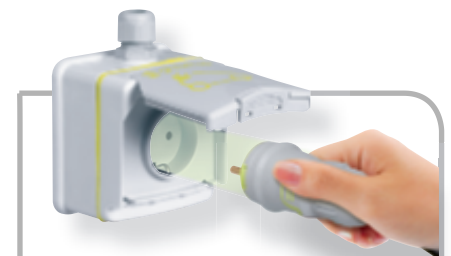

DETECTION SYSTEM PATENTED BY LEGRAND

Vehicles detect the secure Green'up
infrastructure and select the
maximum power that can be
supplied via the socket, resulting
in a shorter charging time.

(1) Average time for full charge according to manufacturer sources, variable depending on the model

GREEN'UP PREMIUM CHARGING STATION



For any electric vehicle model



Shuttered T2S EV Plug socket for mode 3 charging, conforms to European Directives and car manufacturers' requirements



Green'up Access heavy-duty socket for charging in modes 1 & 2 and for all applications

Integrated off-peak control

Automatically charges during off-peak hours, with override button for operation outside the low-tariff period

MODES 1 & 2

MODE 3 COMMUNICATION

Charging time



IP 44 - IK 08
3.7/4.6 kW single-phase



IP 44 - IK 08
7.4 kW single-phase

SOLUTION THAT IS INEXPENSIVE, ADAPTABLE AND SAFE

With the IK 08 and IK 10 Green'up Access socket, Legrand makes it easy to charge vehicles at home and in public car parks. Inexpensive, simple to install, safe, they can also be used for all conventional purposes, and are specially prewired so they can easily be replaced with a mode 3 charging station.



WHEN I'M AT HOME, I CAN CHARGE MY ELECTRIC VEHICLE OVERNIGHT IN COMPLETE SAFETY

READY TO INSTALL GREEN'UP ACCESS

MODES 1 & 2
Charging time

 IP 66 - IK 08
 14 A - 3.2 kW
 single-phase

30 mA
 20 A RCBO - C curve - Detects
 faults with AC and DC components

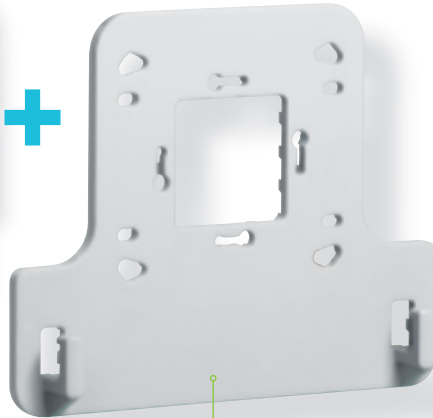

Hanging bracket
 For the charging
 cable control box

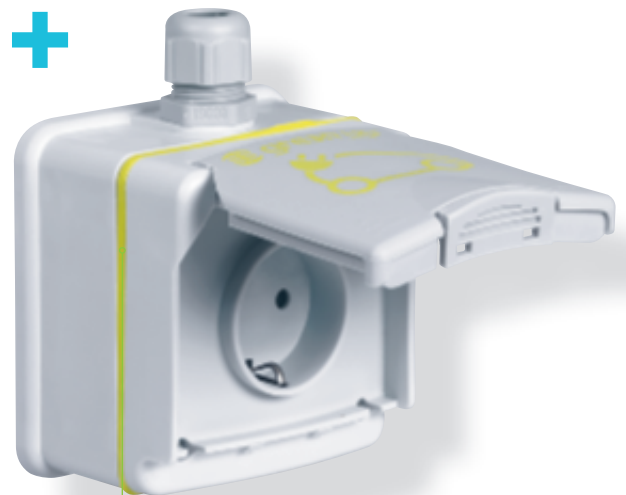

Green'up Access heavy-duty socket
 IP 66 - IK 08 - 25 kWh - 230 V



The Green'up system is based on innovative Legrand Group technology, activating "maximum power" mode and ensuring fast, safe charging

SOLUTION THAT IS INEXPENSIVE AND SAFE, SIMPLE TO INSTALL

With the Green'up Access ready to install kit, Legrand offers anyone the opportunity to install the infrastructure for charging electric vehicles and plug-in hybrids, simply and in complete safety.

Consisting of a Green'up Access heavy-duty socket, a hanging bracket and a 30 mA RCBO, the Ready to install kit is ideal for both private homes and workplaces.

(1) Average time for full charge according to manufacturer sources, variable depending on the model

Green'up™ sockets and charging stations

for electric vehicles and plug-in hybrids



CHARGING MODE	POWER (kW)	MATERIAL	IP	IK	NUMBER OF CHARGING POINTS	WALL FIXING	FLOOR STANDING	AVERAGE CHARGING TIME (IN HOURS) DEPENDING ON THE VEHICLE AND BATTERY TYPE			
								Vehicle battery capacity			
								15/16 kW/h	22/24 kW/h	30/32 kW/h	
SINGLE-PHASE - 230 V											
Mode 2	3.2		Plastic	55	08	1	0 904 70 ⁽¹⁾ 0 904 72	-	6 ⁽²⁾	8 ⁽²⁾	-
	3.2		Metal	55	10	1	0 778 56	-	6 ⁽²⁾	8 ⁽²⁾	-
	3.2		Metal with key	55	10	1	0 778 57	-	6 ⁽²⁾	8 ⁽²⁾	-
Mode 3	3.7/4.6		Plastic	44	08	1	0 590 20	-	4	6	8
	7.4						0 590 29		2.5	3.5	4.5
Modes 2 and 3	3.7/4.6		Plastic	44	08	1	0 590 23	0 590 24	4	6	8
	7.4						0 590 25	0 590 26	3	4	5

1: Ready to install version, supplied with RCBO
 2: For vehicles with cable fitted with Legrand Green'up plug

Green'up™ Access ready to install kit for electric vehicle charging



The Green'up system is based on a innovative Legrand technology, activating "maximum power" mode and ensuring a secure and fast charging process

Complete solution:
mode 2 socket + RCBO



Installation principle **p. 7**
Dimensions **p. 9**

Pack	Cat.Nos	Ready to install kit
1	0 904 70	<p>Allows creating a safe infrastructure for electric and hybrid vehicle charging, using mode 2 (or mode 1) charging cables. Suitable for residential and workplace use</p> <p>Power supply directly from the electrical panel: 1 dedicated line 3 x 2.5 mm² cable, protected with one RCBO (one line per socket)</p> <p>The kit contains:</p> <ul style="list-style-type: none"> - 1 heavy duty German standard Geen'up Access plastic socket, with flap cover, IP 55 - IK 08 - 25 kW/h - 230 V - 8h, 6 mm² screw terminals, according to IEC 60884-1, NF C 61-314, VDE 620-1 - 1 base for hanging up the vehicle charging cable control box - 1 RCBO 20 A, C curve, 30 mA, Hpi type Cat.No 4 107 54 <p>The use of a surge protective device is recommended Recommended installation height; between 0.80 and 1.20 m from the floor</p>

Green'up™ Access sockets 25 kWh / 8h / 230V - for electric vehicles

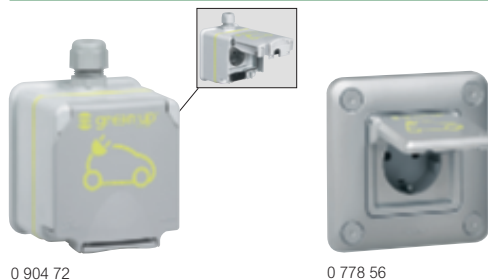



0 904 72

0 778 56

Installation principle **p. 7**
Dimensions **p. 9**

Used for safely charging rechargeable electric and hybrid vehicles which take mode 2 cord (compatible with mode 1)
Connected to the consumer panel via one 3 x 2.5 mm² dedicated line (1 line per socket) protected by 30 mA - 20 A C curve, type A or HPI RCBO (or 30 mA type A or HPI RCCB + 20 A C curve circuit breaker)
Recommended installation height: 1.30 m from the floor
Suitable for residential and workplace use

Pack	Cat.Nos	Mode 1 and mode 2 sockets - 3.2 kVA
1	0 904 72	<p>Heavy-duty mechanisms with silvered contacts Single-phase sockets - screw connection - 230 V Supplied with base Cat.No 0 904 78 for hanging up the vehicle charging cable control box For charging 1 vehicle Conform to IEC 60-884-1</p> <p>IP 55 - IK 08 surface-mounting Suitable for installation in private houses Plastic socket with flap cover Supplied complete with surface mounting box fitted with an ISO 20 cable gland Dimensions (H x W x D): 98 x 98 x 70 mm (exc. cable gland)</p> <p> German standard socket outlet</p>
1	0 778 56	<p>IP 55 - IK 10 flush-mounting - metal socket Suitable for installation in private houses, lock-up garages, parking lots, etc Supplied complete with plate and support Mounting in 1-gang Batibox flush-mounting box depth 50 mm Can be surface mounted with box Cat.No 0 778 90 Dimensions (H x W x D): 110 x 110 x 13.5 mm</p> <p> German standard socket outlet</p>
1	0 778 57	<p>IP 55 - IK 10 flush-mounting - metal socket with locked flap cover Suitable for installation in private houses, lock-up garages, parking lots, etc Supplied complete with plate and support Mounting in 1-gang Batibox flush-mounting box depth 50 mm Can be surface mounted with box Cat.No 0 778 90 Dimensions (H x W x D): 110 x 110 x 13.5 mm Supplied complete with a unique set of 2 keys in order to restrict access to the socket</p> <p> German standard socket outlet</p>

Green'up™ Access sockets

Single-phase Green'up™ Premium charging stations



Installation principle for an individual mode 2 socket

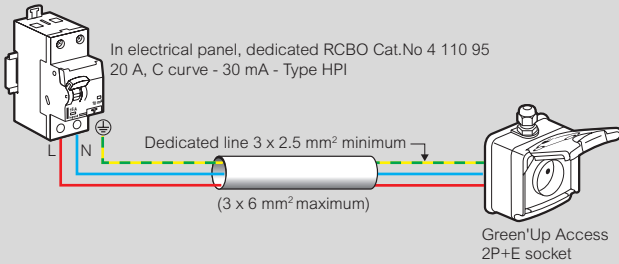

- Can be controlled by clock/switch type control units, etc (to be ordered separately)
- Use of a surge protective device is recommended

Use of bracket Cat.No 0 904 78

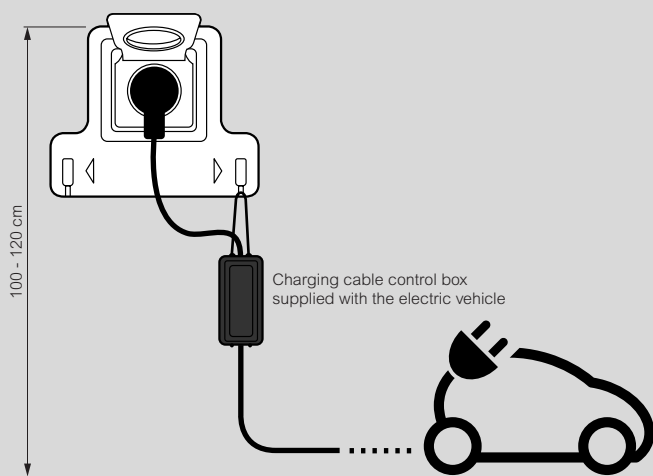

Charging stations
compliant with ZE
Ready⁽¹⁾ specifications

With power adjustment
function

Integrated
residual current
protection



0 590 29



0 590 23



0 590 24

Technical characteristics and wiring diagrams **p.8**

For charging all electric vehicles (equipped with single-phase and three-phase chargers) and plug-in hybrids supplied in mode 2 or in mode 3 in complete safety.

Comply with standards IEC 61851-1 and 61851-22

Charging station power can be adjusted with adapted protection devices and power supply circuits

Equipped with:

- a 2P+E socket (except Cat.Nos 0 590 20 and 0 590 29) with Green'up Access safety shutter benefiting from the innovative Green'up system, a Legrand Group technology which activates "maximum power" mode, ensuring fast, safe charging for 2P+E (mode 2) plugs
- a 3P+N+E (T2S) type 2 socket with blanking plates (single-phase operation) with pilot wire (mode 3)

Electrical panel connected and protected via 1 protected dedicated line
Can be controlled by clock/switch type control units, etc (230 V signal input)

Single-phase - 230 V

Pack	Cat.Nos	Plastic 3.7/4.6 kW - 16/20 A charging station - Mode 3
1	0 590 20	IP 44 - IK 08 Adjustable power Wall fixing For charging 1 vehicle
1	0 590 29	Plastic 5.8/7.4 kW - 25/32 A charging station - Mode 3 IP 44 - IK 08 Adjustable power Wall fixing For charging 1 vehicle
1	0 590 23	Plastic 3.7/4.6 kW - 16/20 A charging station - Modes 2 and 3 IP 44 - IK 08 Adjustable power Wall fixing For charging 1 vehicle
1	0 590 24	On metal pedestal For charging 1 vehicle
1	0 590 25	Plastic 7.4 kW/32 A charging stations - Modes 2 and 3 IP 44 - IK 08 Charging station power can be set to 5.7 kW/25 A single-phase with adapted protection devices and power supply circuits Wall fixing 3 cable entries for connection For charging 1 vehicle
1	0 590 26	On metal pedestal For charging 1 vehicle

(1): Charging stations compliant with ZE Ready 1.2 specifications for construction rules applicable to these products. ZE Ready is a registered trademark of Renault



Installation principle

Wall mounting charging stations

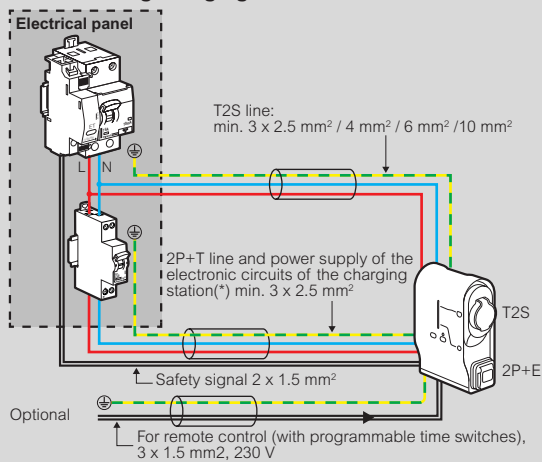

* : Except Cat.No 0 590 20 and charging stations set to 16 A / 3.7 kW

Self-standing charging stations

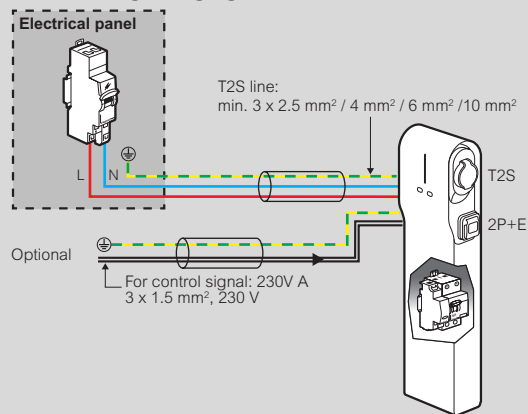

Cat.Nos	0 590 20		0 590 29		0 590 23		0 590 25		
Power adjustment (kW)	3.7	4.6	5.8	7.4	3.7	4.6	5.8	7.4	
Charging station rated current (A)	16	20	25	32	16	20	25	32	
Residual current protection	30 mA Hpi	30 mA Hpi	30 mA Hpi	30 mA Hpi	30 mA Hpi	30 mA Hpi	30 mA Hpi	30 mA Hpi	
Minimum cross section of the T2S cable (mm ²)	2.5	4	6	10	2.5	4	6	10	
Rated current & tripping curve of the MCB protecting the T2S line	20 A C curve	25 A C curve	32 A C curve	40 A C curve	20 A C curve	25 A C curve	32 A C curve	40 A C curve	
T2S line protection	by RCBO ⁽¹⁾⁽²⁾	4 110 95	4 110 96	4 110 97	4 110 98	4 110 95	4 110 96	4 110 97	4 110 98
	by RCCB + MCB ⁽¹⁾⁽²⁾	4 115 91 + 4 077 43	4 115 91 + 4 077 44	4 115 91 + 4 077 45	4 115 91 + 4 077 46	4 115 91 + 4 077 43	4 115 91 + 4 077 44	4 115 91 + 4 077 45	4 115 91 + 4 077 46
Min. cross section of the cable supplying Green'Up Access 2P+E socket (mm ²)	Not concerned		Not concerned		Same line as T2S socket		2.5	2.5	2.5
Rated current & tripping curve of the RCBO protecting the line supplying Green'Up Access 2P+E socket	Not concerned		Not concerned		Same protection as T2S line		20 A C curve	20 A C curve	20 A C curve
RCBO for the line supplying the Green'Up Access 2P+E socket	Not concerned		Not concerned		Same protection as T2S line		4 077 43	4 077 43	4 077 43
Current shunt trip / safety signal	4 062 76		4 062 76		4 062 76		4 062 76	4 062 76	4 062 76
Surge protective device (SPD) ⁽²⁾	4 122 26 + 4 078 01		4 122 26 + 4 078 01		4 122 26 + 4 078 01		4 122 26 + 4 078 01	4 122 26 + 4 078 01	4 122 26 + 4 078 01

1 : Breaking capacity 6000/10 kA;

For other breaking capacities: please consult the technical sheet available on E-Catalogue

2 : Neutral on right-hand side.

For neutral on left-hand side: please consult the technical sheet available on E-Catalogue

Cat.Nos	0 590 24		0 590 26		
Power adjustment (kW)	3.7	4.6	5.8	7.4	
Charging station rated current (A)	16	20	25	32	
Residual current protection: 30 mA Hpi	Integrated into the station	Integrated into the station	Integrated into the station	Integrated into the station	
Rated current & tripping curve of the MCB protecting the T2S line	20 A C curve	25 A C curve	32 A C curve	40 A C curve	
Minimum cross section of the T2S cable (mm ²)	2.5	4	6	10	
T2S line protection	by MCB ⁽¹⁾	4 077 43 (6000/10kA)	4 077 44 (6000/10kA)	4 077 45 (6000/10kA)	4 077 46 (6000/10kA)
	by RCBO	4 110 95 (6000/10kA)	4 110 96 (6000/10kA)	4 110 97 (6000/10kA)	4 110 98 (6000/10kA)
Current shunt trip / safety signal	Integrated into the station	Integrated into the station	Integrated into the station	Integrated into the station	
Surge protective device (SPD)	4 122 21 + 4 078 01	4 122 21 + 4 078 01	4 122 21 + 4 078 01	4 122 21 + 4 078 01	

1 : Neutral on right-hand side

For other breaking capacities, neutral on left-hand side: please consult the technical sheet available on E-Catalogue

Green'up™ Access sockets

Single-phase Green'Up™ Premium charging stations

■ Dimensions

Cat.No 0 904 72

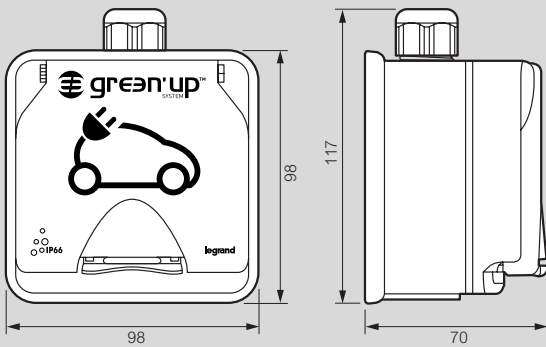

Cat.No 0 904 78

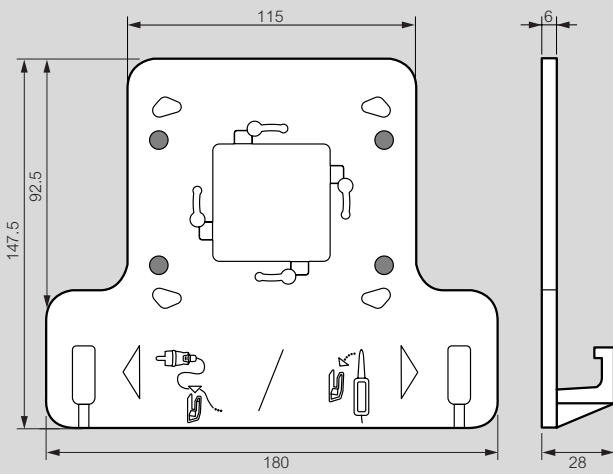

Cat.No 0 778 56

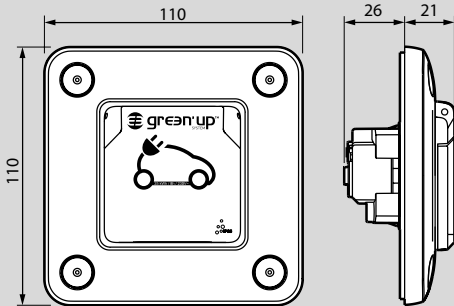

Cat.No 0 778 57

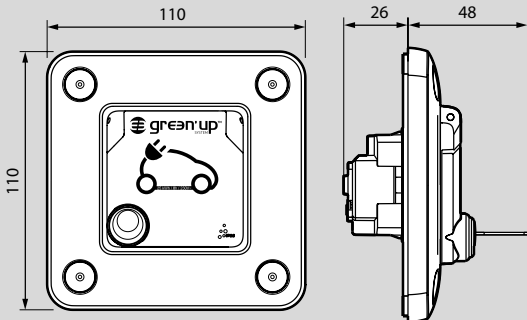

■ Dimensions and fixing (mm)

Wall-mounting charging stations

Cat.Nos 0 590 20/23/25/29

Weight: 3.75 kg

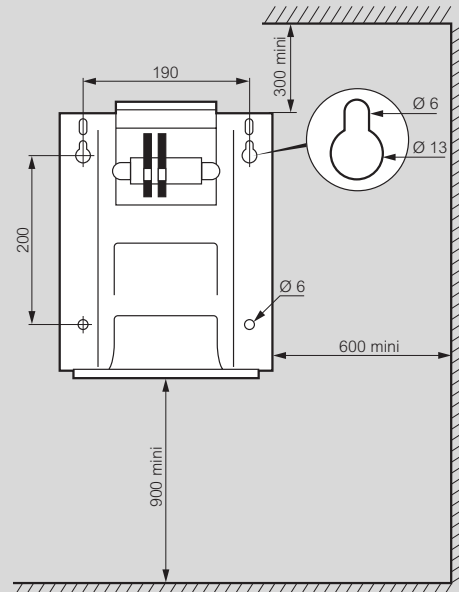
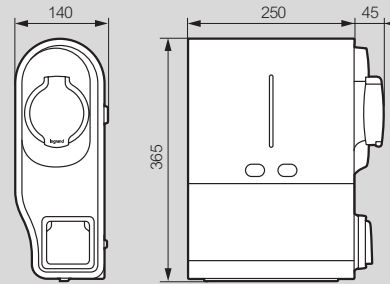

Self-standing charging stations

Cat.Nos 0 590 24/26

Weight: 18.20 kg

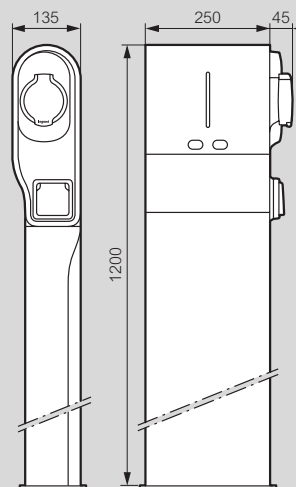

Floor fixing

For Cat.Nos 0 590 24/26

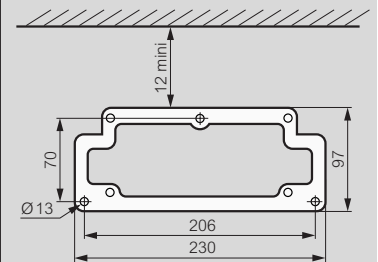



FOLLOW US ALSO ON

@ legrand.com

 youtube.com/user/legrand

 facebook.com/Legrand

 twitter.com/Legrand

 pinterest.com/legrandgroup

 instagram.com/legrandnews



Head office

and International Department
87045 Limoges Cedex - France
Tel. : + 33 (0) 5 55 06 87 87
Fax: + 33 (0) 5 55 06 74 55